

involgia
Curated Bath Brands



CRISTINA
RUBINETTERIE





ITALY

BATHROOM

 **CRISTINA**
RUBINETTERIE

Disegnata da Busetti Garuti Redaelli, e premiata nel 2017 con l' Archiproducts Award, la serie Italy rilegge in chiave moderna i classici stilemi degli anni Venti. Eleganza, raffinatezza e l'utilizzo di materiali quali marmo e pietre ne sono i tratti caratteristici. Con questa serie si ha la possibilità di abbinare numerose finiture a varie essenze di marmo o pietre, per un totale di quasi 50 combinazioni. In questo modo, il miscelatore può essere scelto in funzione di un gusto personale. Nel dettaglio, i bordi delle manopole sono caratterizzati da una lavorazione tipica del cristallo e del taglio delle pietre preziose. I rosoni, alla base del miscelatore, si ispirano alle boiserie delle sale da bagno tipiche dell'epoca. Le maniglie vengono ricavate dalla lavorazione di un blocco pieno, di marmo o pietra che, con la loro matericità e cromia determinano tutto l'insieme del progetto. Il corpo del miscelatore è realizzato in fusione di ottone, mentre nella forma rettangolare della bocca di erogazione è alloggiato un rompigitto che va a garantire un flusso d'acqua uniformemente a cascata. Proposta in diverse declinazioni, la serie Italy è facilmente contestualizzabile sia in ambienti classici che contemporanei.

The Italy series, designed by Busetti Garuti Redaelli, and which in 2017 won the Archiproducts Award, gives a modern twist to the classic styles popular in the 1920s. Elegance, sophistication, and the use of materials such as marble and stone are its distinctive features. With this series you have the possibility to blend a variety of finishes with several types of marble or stone, for a total of almost 50 combinations. In this way, the mixer tap can be chosen according to one's personal taste. More specifically, the edges of the knobs are characterised by a typical crystal machining process as well as the cutting of precious stones. The roses at the base of the mixer taps are inspired by the millwork of the bathroom typical of that period. The handles are obtained from the processing of a solid block of marble or stone that with their materic effect and colour determine the whole project. The body of the mixer tap is made of cast brass, while a flow regulator is housed in the rectangular spout, to ensure a uniform cascade-like outflow of water. The Italy series is available in a variety of styles and therefore can easily be contextualised in both classical and contemporary environments.

Vom Designer Busetti Garuti Redaelli entworfen und 2017 mit dem Archiproducts Award ausgezeichnet interpretiert die Serie Italy unter modernem Gesichtspunkt die klassischen Stilelemente der zwanziger Jahre. Eleganz, Feinheit und die Verwendung von Materialien wie Marmor und Steinen sind die charakteristischen Merkmale. Mit dieser Serie ist es möglich, zahlreiche Oberflächen mit verschiedenen Marmor- oder Steinsorten zu kombinieren, was insgesamt fast 50 Kombinationen ermöglicht. Auf diese Weise kann die Armatur nach persönlichem Geschmack ausgewählt werden. Die Kanten der Griffe zeichnen sich durch eine typische Verarbeitung und Schnitt des Kristalls von Edelsteinen aus. Die Rosetten der Armaturen inspirieren sich nach der Boiserie der damaligen Badezimmer. Die Griffe werden aus der Verarbeitung eines massiven Marmor- oder Steinstücks gewonnen und bestimmen mit deren Eigenschaften und Farben das gesamte Projekt. Der Armaturenkörper ist aus Messingguss, während der rechteckige Auslauf ist mit einem Strahlregler ausgestattet, um einen gleichmäßigen Wasserstrahl zu gewährleisten. Die Serie Italy passt in ihrer verschiedenen vorgeschlagenen Kombinationen sowohl zu klassischen als auch zu modernen Ambienten.

Conçue par Busetti, Garuti & Redaelli, et récompensée en 2017 par le prix Archiproducts, la gamme Italy réinterprète les styles classiques des années 1920 dans une tonalité moderne. L'élégance, le raffinement et l'utilisation de matériaux tels que le marbre et la pierre sont ses caractéristiques. Avec cette série, vous avez la possibilité de combiner de nombreuses finitions avec différentes essences de marbre ou de pierre, pour un total avoisinant les 50 combinaisons. De cette façon, le mitigeur peut être choisi en fonction des goûts personnels. En détail, les bords des poignées sont caractérisés par un traitement typique du cristal et la taille de pierres précieuses. Les rosaces, à la base du mélangeur, sont inspirées des revêtements de salle de bains typiques de l'époque. Les poignées sont obtenues en travaillant un bloc massif de marbre ou de pierre qui, par leur matière et leur couleur, déterminent l'ensemble du projet. Le corps du mitigeur est en laiton, tandis que dans la forme rectangulaire du bec, un mousseur garantit un écoulement uniforme de l'eau en cascade. Proposée dans différentes déclinaisons, la gamme Italie est facilement contextualisée dans des environnements tant classiques que contemporains.





I designer Busetti Garuti Redaelli raccontano: "Abbiamo definito nuove forme e volumi che reinterpretano gli ideali canonici della classicità, dove le sfaccettature che moltiplicano i riflessi rimandano a lavorazioni tipiche del cristallo e del taglio di pietre preziose."

The designers Busetti Garuti Redaelli say: "We have defined new forms and volumes that reinterpret classic canonical ideals, where the reflective surfaces remind us of typical crystal processing and cutting of precious stones."

Die Designer Busetti, Garuti und Redaelli erklären: "Wir haben neue Formen und Volumen definiert, Ideale der Klassik neu interpretiert: die Facetten, die die Glanzlichter vermehren, verweisen auf die Bearbeitung des Kristallglases zu Juwelen".

Les designers Busetti Garuti Redaelli racontent: "Nous avons défini de nouvelles formes et volumes qui réinterprètent les idéaux canoniques classiques, dont les facettes aux multiples reflets, reportent aux techniques de taille typique des cristaux et des pierres précieuses"

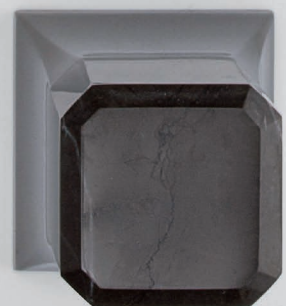
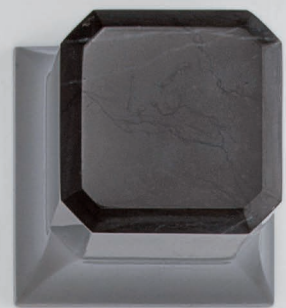

MARBLE & STONES

Importanti e nobili materiali, dal carattere forte e unico, in numerose finiture che offrono ampia possibilità di personalizzazione. Il corpo in ottone, dalle linee delicatamente austere, può essere declinato in diverse finiture galvaniche, le manopole in numerose essenze di marmo o pietra. Italy si configura come un progetto di grande forza espressiva che coinvolge visivamente e tattilmente con la sua bellezza naturale.

Important, noble materials, with a strong, unique identity come in a number of finishes that offer a wide range of options to suit your personal style. The brass body, with its gently austere lines, can be offered in several galvanic finishes, and the knobs in numerous marble or stone essences. Italy is a project whose highly expressive force visually and tactfully engages you with its natural beauty.

Wertvolle- und edle Materialien, kraftvolle und einzigartige Strukturen in einer Vielfalt in der Oberflächen, die verschiedenen Möglichkeiten der individuellen Gestaltung. Der Messingkörper mit sanft strengen Linien ist in verschiedenen galvanischen Farben erhältlich. Die Griffe in zahlreiche Essenzen aus Marmor oder Stein kombinierbar. Italy ist ein Projekt mit großer Ausdruckskraft, das visuell und haptisch mit seiner natürlichen Schönheit fasziniert.

Des matériaux importants et nobles, avec un caractère fort et unique, dans de nombreuses finitions qui offrent une large gamme d'options de personnalisation.

Le corps en laiton, avec ses lignes légèrement austères, se présente dans plusieurs finitions galvaniques, les poignées dans nombreuses essences de marbre ou de pierre. Italy est un projet d'une grande force d'expression qui sensibilise au touché et au niveau visuel par sa beauté naturelle.

FINITURE /FINISHINGS

L'altissima qualità delle finiture, ottenute tramite processo galvanico, è curata da esperti altamente qualificati che lavorano come alchimisti per assicurare alle superfici, sia lucide sia spazzolate, elevati standard tecnici ed estetici. Con la stessa cura i marmi e le pietre vengono selezionati e trattati per mantenere nel tempo le originarie caratteristiche estetiche.

The top quality finishes, obtained through galvanic processes, are carefully managed by qualified engineers whose quasi-chemist skill ensures that the polished or brushed surfaces meet with the highest technical and aesthetic standards. With the same care, marbles and stones are selected and treated in order to maintain their original aesthetic features over time.

Die hohe Qualität der Farben, die durch das galvanische Verfahren hergestellt werden, wird von hoch qualifizierten Fachleuten verfolgt, die wie Alchemisten arbeiten, um hohe technische und ästhetische Standards bei den glänzenden sowie den gebürsteten Oberflächen zu gewährleisten. Mit der gleichen Sorgfalt werden Marmor und Steine ausgewählt und behandelt, um die ursprünglichen ästhetischen Eigenschaften im Laufe der Zeit aufrechtzuerhalten.

La haute qualité de finition, obtenue par procédé galvanique, est suivie par des experts hautement qualifiés qui, comme des alchimistes, dédient leur travail pour obtenir des surfaces, soit brillantes que brossées, avec des standards techniques et esthétiques élevés. Avec le même soin, les marbres et les pierres sont sélectionnés et traités pour maintenir les caractéristiques esthétiques originales au fil du temps.



YOUR CHOICE

La serie, con circa 50 possibilità tra abbinamenti cromatici e materici, rappresenta un elemento d'arredo esteticamente importante, che contribuisce a definire l'atmosfera dell'ambiente bagno e riflettere la personalità di chi lo abita.

With about 50 different colour and material combinations, the range is an important and attractive furnishing accessory that helps to create the bathroom atmosphere and to reflect the personality of those who live in it.

Mit ca. 50 verschiedenen möglichen Kombinationen aus Farben und Materialien, repräsentiert die Serie ein ästhetisch exklusives Einrichtungs-element: Das besondere Ambiente des Bades unterstreicht die Persönlichkeit der Eigentümer.

Comptant environ 50 possibilités de combinaisons des couleurs et des matériaux, la série représente un élément esthétiquement important dans la définition de l'atmosphère de la salle de bain et dans l'expression de la personnalité de ceux qui y vivent.



FINITURE / FINISHINGS

Metalliche
Metallic
Metallische Farben
Métalliques



51 Cromo
Chrome
Chrom
Chromé



72 Cromo nero lucido
polished black chrome
Schwarz Chrom glänzend
Chromé noir

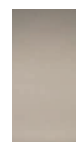

80 Metallic lucido
Polished metallic
Metallic glänzend
Métal brillant



52 Oro giallo
Yellow gold
Gelbgold
Doré



77 Metallic spazzolato
Brushed metallic
Metallic gebürstet
Métal brossé



46P Oro rosa lucido PVD
Polished rose gold PVD
Rosé-Gold glänzend PVD
Or rosePVD



75 Cromo nero spazzolato
Brushed black chrome
Schwarz Chrom gebürstet
Chromé noir brossé

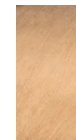

34P Oro rosa spazzolato PVD
Brushed rose gold PVD
Rosé-Gold gebürstet PVD
Or rose brossé PVD

Marmi e pietre
Marbles and stones
Marmor und Steine
Métal et pierres



QZ Quarzite velvet
Quartzite velvet
Quarzit samtig
Quartzite velours



CC Calacatta lucido
Polished Calacatta
Calacatta glänzend
Calacatta brillant



CR Crema nuova velvet
Crema nuova velvet
Crema nuova samtig
Crema nuova velours



MQ Marquinia lucido
Polished Marquinia
Marquinia glänzend
Marquinia brillant



GF Grafite lucida
Polished Graphite
Graphit glänzend
Graphite brillant



VG Guatemala lucido
Polished Guatemala
Guatemala glänzend
Guatemala brillant

MOOD TIPS

Accanto alle soluzioni total look, CRISTINA propone quattro combinazioni materiche e cromatiche che soddisfano le diverse esigenze arredative, dei settori residenziale e contract.

In addition to the total look solutions, CRISTINA offers four colour and material combinations that meet the various interior furnishing needs of the residential and contract sectors.

CRISTINA bietet vier mögliche Kombinationen, die dem Stil des Wohn- und Objekt-Bereiches entsprechen.

En complément des solutions total look, CRISTINA propose quatre combinaisons de matériaux et de couleurs qui répondent aux différentes exigences liées au design d'intérieur des secteurs résidentiels et des projets.

MOOD RAW



QZ
77

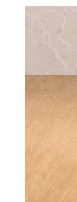

CR
34



MQ
75

MOOD PURE



CR
80



QZ
51

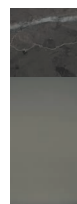

GF
72

MOOD STYLISH



CC
51



CC
46

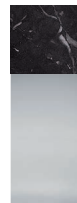

MQ
51

MOOD SUMPTUOUS

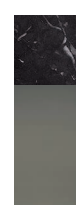

MQ
72



CC
52

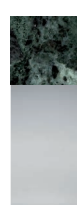

VG
51

MOOD RAW



MOOD RAW

Ispirata all'atmosfera sofisticata e rilassante tipica delle SPA, questa proposta prevede una palette cromatica che valorizza le tonalità calde e naturali, tipiche del mondo della natura, come la sabbia dorata e la terra grezza. Il risultato finale è la grande forza espressiva della materia.

Inspired by the sophisticated and relaxing atmosphere typical of SPAs, this proposal provides a chromatic palette that enhances the warm and natural shades, which are distinctive features of the world of nature, such as golden sand and rough earth. The end result is the highly expressive force of the material.

Von der anspruchsvollen und entspannenden Atmosphäre einiger SPA' s inspiriert, bietet die Serie eine Farbpalette warmer und natürlicher Töne wie goldenen Sand und Ton. Die große Ausdruckskraft des Materials unterstreicht die typische Vielfalt der Natur.

Inspirée par l'atmosphère sophistiquée et relaxante, typique des SPA, cette proposition offre une palette chromatique qui met en évidence les nuances chaudes et naturelles, qui évoquent le monde de la nature, comme le sable doré et la terre brute. La grande force d'expression de la matière en est le résultat final.



CRIIT220_77_QZ >

Metallic spazzolato - Quarzite velvet
Brushed metallic - Quartzite velvet
Metallic gebürstet - Quarzit samtig
Métal brossé - Quartzite velours

Metallic spazzolato - Quarzite velvet
Brushed metallic - Quartzite velvet
Metallic gebürstet - Quarzit samtig
Métal brossé - Quartzite velours



CRIT121_77_QZ



< CRIT220_77_QZ



Oro rosa spazzolato - Crema nuova velvet
Brushed rose gold - Crema nuova velvet
Rosé-Gold gebürste - Crema nuova samtig
Or rose brossé - Crema nuova velours

CRIT220_34_CR



Cromo nero spazzolato - Marquina lucido
Brushed black chrome - Polished Marquina
Schwarz Chrom gebürstet - Marquina glänzend
Chromé noir brossé - Marquina brillant



CRIT227_75_MQ



MOOD PURE



DO
MORE
OF
WHAT
MAKES
YOU
HAPPY

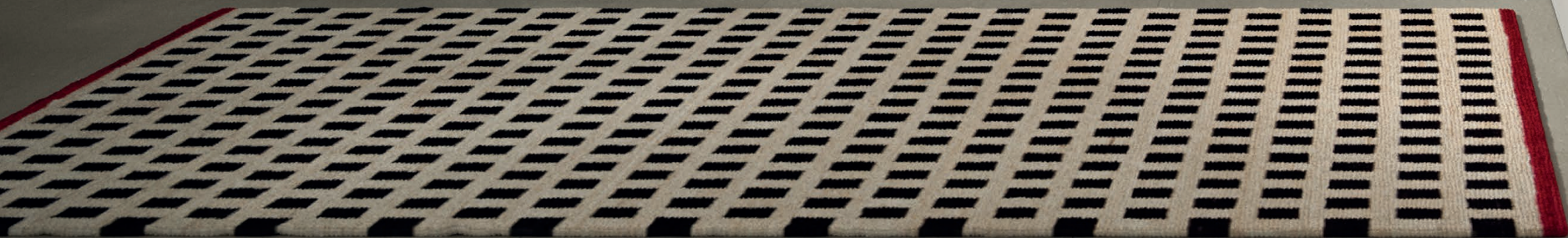

MOOD PURE

Un ambiente bagno libero dai tradizionali canoni estetici che, in un percorso di continuità, si avvicina alle altre stanze della casa. In questa proposta, colore e finiture esprimono un lusso contemporaneo e discreto, che predilige l'utilizzo di finiture metalliche per il corpo rubinetto, abbinato a preziosi marmi dalle eleganti striature.

A bathroom space with no traditional aesthetic limits, that approaches the other rooms of the house with progressive harmony. A suggestion of colour and finishes to enhance a contemporary and discreet luxury, focusing on metal finishes for the tap body, combined with precious marbles with elegant streaks.

Ein Bad-Ambiente frei von den traditionellen ästhetischen Kriterien, das die anderen Räume des Hauses einbezieht. Farbe und Oberflächen strahlen einen zeitlosen und diskreten Luxus aus. Hier wird die Kombination aus metallischen Oberflächen für den Armaturenkörper und wertvollem Marmor für die Griffe bevorzugt.

Une salle de bain sans limites esthétiques traditionnelles qui permet de s'approcher progressivement et avec continuité, aux autres pièces de la maison. Dans cette proposition, la couleur et les finitions expriment un luxe contemporain et discret, qui opte pour l'utilisation de finitions métalliques pour le corps du robinet, combiné avec des marbres précieux striés de veines élégantes.



CRIT205_80_CR >

Metallic lucido - Crema nuova velvet
Polished metallic - Crema nuova velvet
Metallic glänzend - Crema nuova samtig
Métal brillant - Crema nuova velours

Metallic lucido - Crema nuova velvet
Polished metallic - Crema nuova velvet
Metallic glänzend - Crema nuova samtig
Métal brillant - Crema nuova velours



CRIT121_80_CR



< CRIT205_80_CR



Cromo - Quarzite velvet
Chrome - Quarzite velvet
Chrom - Quarzit samtig
Chromé - Quarzite velours

CRIT242_51_QZ

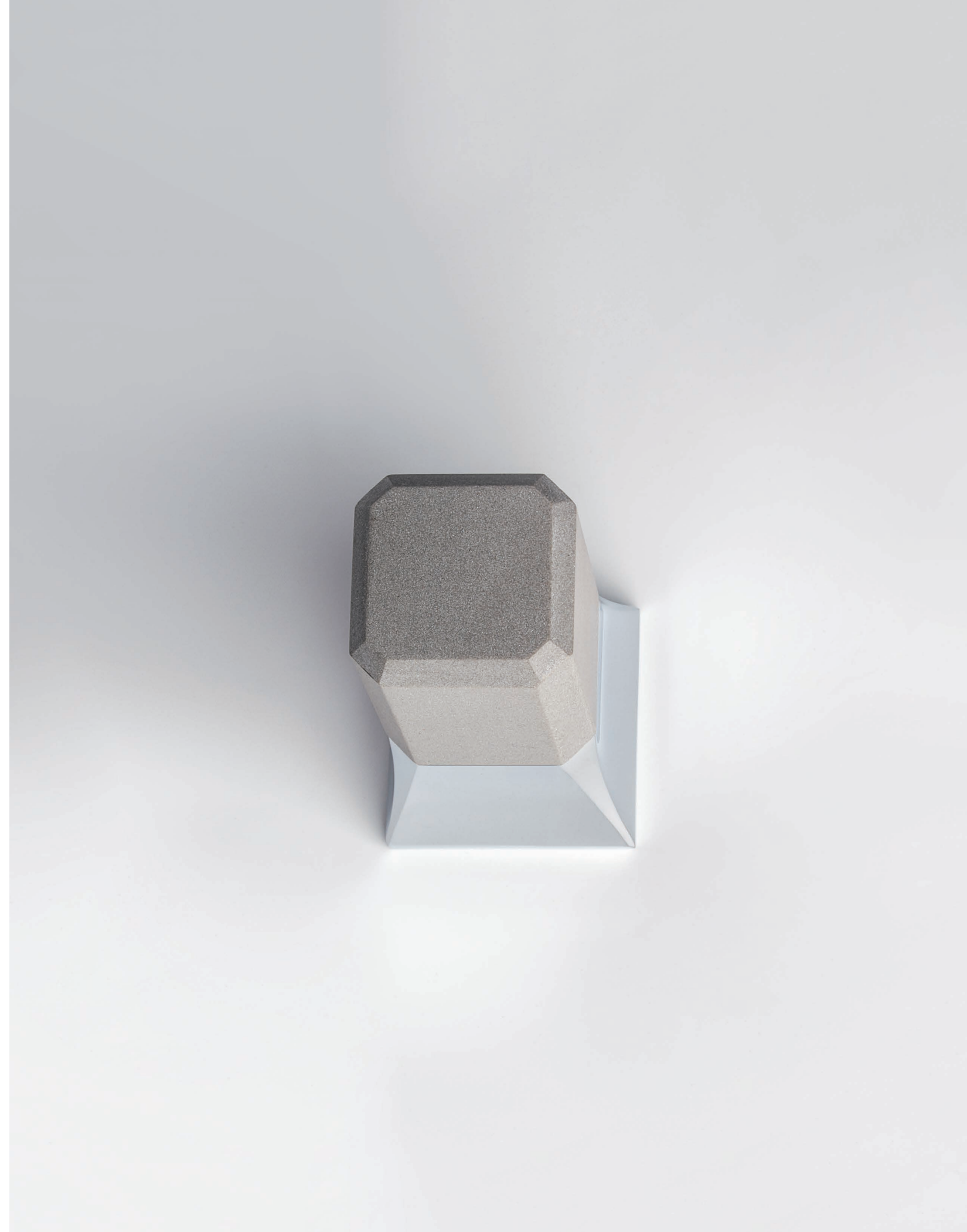

Cromo nero lucido - Grafite lucida
Polished black chrome - Polished Graphite
Chrom Schwarz glänzend - Graphit glänzend
Chromé noir - Graphite brillant



CRIT165_72_GF



< CRIT280_72_GF



MOOD STYLISH



MOOD STYLISH

Una combinazione sofisticata che celebra i marmi Calacatta e Marquina, simbolo dell'eleganza più assoluta. In questo mood, la preziosità e la purezza della pietra bianca e nera, vengono accostate a corpi brillanti e lucidi, dando vita a composizioni dal contrasto materico e cromatico.

A sophisticated combination that celebrates Calacatta and Marquina marbles, symbols of exquisite elegance. In this mood, the preciousness and purity of white and black stone coupled with bright, shiny bodies, create material and chromatic contrasts.

Eine anspruchsvolle Kombination mit dem Marmor Calacatta und Marquina, die für eine exklusive Eleganz steht. In dieser Konfiguration werden die Kostbarkeit und die Reinheit des schwarzen und weißen Steines mit brillanten und glänzenden Körpern kombiniert. Dadurch entstehen Kontraste aus Material und Farbe.

Une combinaison sophistiquée qui célèbre les marbres Calacatta et Marquina, symbole de la plus grande élégance. Dans ce mood, la préciosité et la pureté de la pierre blanche et noire sont alliées à des corps luisants et brillants, créant un contraste chromatique et de matériaux dans les compositions.



CRIIT243_51_CC >

Cromo - Calacatta lucido
Chrome - Polished Calacatta
Chrom - Calacatta glänzend
Chromé - Calacatta brillant

Cromo - Calacatta lucido
Chrome - Polished Calacatta
Chrom - Calacatta glänzend
Chromé - Calacatta brillant



CRIT165_51_CC



< CRIT243_51_CC



Oro rosa lucido - Calacatta lucido
Polished rose gold - Polished Calacatta
Rosé-Gold glänzend - Calacatta glänzend
Or rose - Calacatta brillant

CRIT121_46_CC



CRIT243_51_MQ



MOOD SUMPTUOUS



MOOD SUMPTUOUS

Per coloro che desiderano lo stile più esclusivo e ricercato, CRISTINA rubinetterie propone combinazioni materiche di forte impatto visivo, pensate per chi ama osare. Attraverso la scelta dell'oro giallo, del marmo verde Guatemala o del Cromo nero lucido è possibile personalizzare l'ambiente bagno con preziosi dettagli di luce.

For those who desire the most exclusive and refined style and want to dare, CRISTINA rubinetterie offers material combinations with great visual effects. Explore the choice of yellow gold, green Guatemala marble or shiny black chrome, to create your personal style in the bathroom with precious light details.

Für diejenigen, die den exklusivsten und anspruchsvollsten Stil lieben, bietet CRISTINA rubinetterie Materialkombinationen mit starkem visuellen Effekt. Durch die Wahl von Gelbgold, grünem Marmor Guatemala oder schwarzem Chrom glänzend ist es möglich, das Bad in einem exklusivem Licht erstrahlen zu lassen.

Pour les plus audacieux, qui désirent un style plus exclusif et plus recherché, CRISTINA Rubinetterie propose des combinaisons de matériaux avec un fort impact visuel. De l'or jaune, du marbre vert Guatemala ou du chromé noir brillant, au choix, pour une ambiance bain personnalisée avec des précieux détails lumineux.

CRIT205_72_MQ >
Cromo nero lucido - Marquina lucido
Polished black chrome - Polished Marquina
Schwarz Chrom glänzend - Marquina glänzend
Chromé noir- Marquina brillant



Cromo nero lucido - Marquina lucido
Polished black chrome - Polished Marquina
Schwarz Chrom glänzend - Marquina glänzend
Chromé noir- Marquina brillant



CRIT165_72_MQ



< CRIT205_72_MQ



Oro rosa giallo - Calacatta lucido
Yellow gold - Polished Calacatta
Gelbgold - Calacatta glänzend
Doré - Calacatta brillant

CRIT205_52_CC



Cromo - Guatemala lucido
Chrome - Polished Guatemala
Chrom - Guatemala glänzend
Chromé - Guatemala brillant



CRIT205_51_VG





TECHNICAL INFO

LAVABO - BIDET
WASHBASIN - BIDET

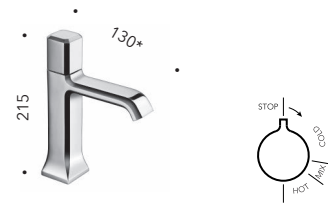

CRIIT210

Miscelatore monocomando progressivo per lavabo REGULAR con scarico Up&Down da 1"1/4

Progressive basin mixer REGULAR with 1"1/4 Up&Down waste



CRIIT220

Miscelatore monocomando REGULAR per lavabo con scarico Up&Down da 1"1/4

Basin mixer REGULAR with 1"1/4 Up&Down waste



CRIIT217

Miscelatore monocomando progressivo per lavabo MEDIUM con scarico Up&Down da 1"1/4

Progressive basin mixer MEDIUM with 1"1/4 Up&Down waste

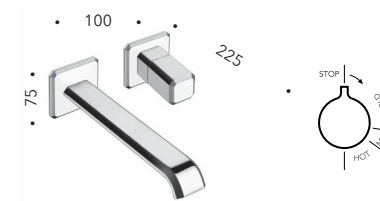

CRIIT249

Set da esterno miscelatore monocomando progressivo lavabo LARGE per CRICS200 (comando destro) - CRICS201 (comando sinistro) con scarico Up&Down da 1"1/4

Progressive wall mounted basin mixer LARGE external parts for CRICS200 (right side) - CRICS201 (left side) with 1"1/4 Up&Down waste

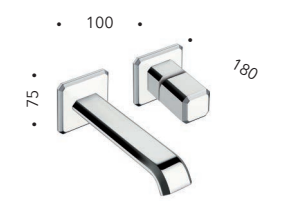

CRIIT257

Set da esterno miscelatore monocomando lavabo REGULAR per CRICS200 (comando destro) - CRICS201 (comando sinistro) con scarico Up&Down da 1"1/4

Wall mounted basin mixer REGULAR external parts for CRICS200 (right side) - CRICS201 (left side) with 1"1/4 Up&Down waste

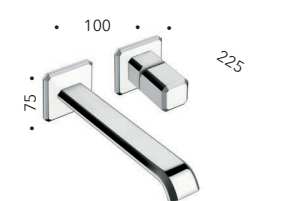

CRIIT259

Set da esterno miscelatore monocomando lavabo LARGE per CRICS200 (comando destro) - CRICS201 (comando sinistro) con scarico Up&Down da 1"1/4

Wall mounted basin mixer LARGE external parts for CRICS200 (right side) - CRICS201 (left side) with 1"1/4 Up&Down waste



CRIIT227

Miscelatore monocomando MEDIUM per lavabo con scarico Up&Down da 1"1/4

Basin mixer MEDIUM with 1"1/4 Up&Down waste

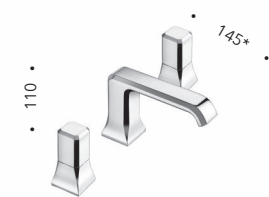

CRIIT205

Miscelatore bicomando REGULAR per lavabo 3 fori con scarico Up&Down da 1"1/4

3 hole basin mixer REGULAR with 1"1/4 Up&Down waste

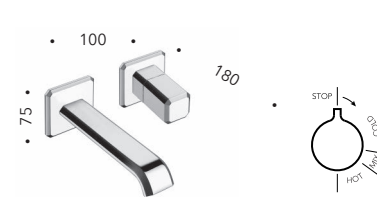

CRIIT247

Set da esterno miscelatore monocomando progressivo lavabo REGULAR per CRICS200 (comando destro) - CRICS201 (comando sinistro) con scarico Up&Down da 1"1/4

Progressive wall mounted basin mixer REGULAR external parts for CRICS200 (right side) - CRICS201 (left side) with 1"1/4 Up&Down waste

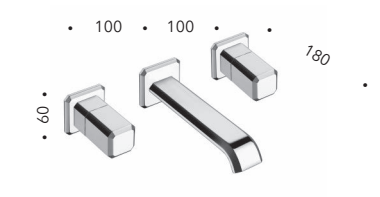

CRIIT242

Set da esterno miscelatore bicomando lavabo REGULAR per CRICS233 (comandi laterali) - CRICS234 (comando destro) con scarico Up&Down da 1"1/4

Wall mounted basin mixer REGULAR external parts for CRICS233 (side controls) - CRICS234 (right side) with 1"1/4 Up&Down waste

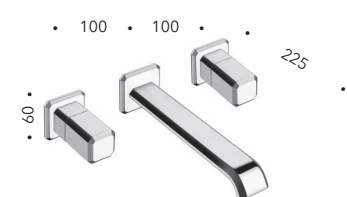

CRIIT243

Set da esterno miscelatore bicomando lavabo LARGE per CRICS233 (comandi laterali) - CRICS234 (comando destro) con scarico Up&Down da 1"1/4

Wall mounted basin mixer LARGE external parts for CRICS233 (side controls) - CRICS234 (right side) with 1"1/4 Up&Down waste

TECHNICAL INFO

LAVABO - BIDET
WASHBASIN - BIDET

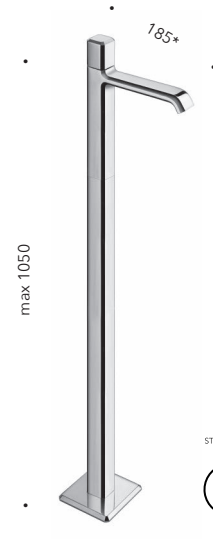

CR11T280

Set da esterno per miscelatore monocomando progressivo lavabo a pavimento CRICS290 con scarico Up&Down da 1"1/4

Floor mounted progressive basin mixer external parts for CRICS290 with 1"1/4 Up&Down waste

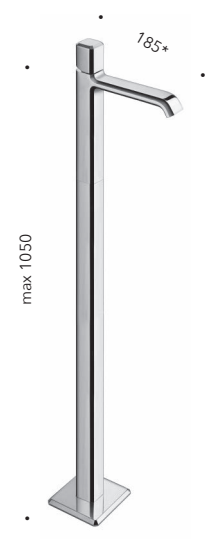

CR11T290

Set da esterno per miscelatore monocomando lavabo a pavimento CRICS290 con scarico Up&Down da 1"1/4

Floor mounted basin mixer external parts for CRICS290 with 1"1/4 Up&Down waste



CR11T310

Miscelatore monocomando progressivo per bidet con scarico Up&Down da 1"1/4

Progressive bidet mixer with 1"1/4 Up&Down waste



CR11T320

Miscelatore monocomando per bidet con scarico Up&Down da 1"1/4

Bidet mixer with 1"1/4 Up&Down waste

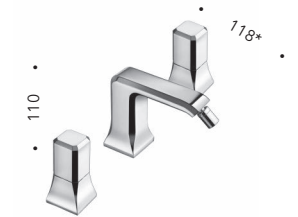

CR11T307

Miscelatore bicomando per bidet 3 fori con scarico Up&Down da 1"1/4

3 hole bidet mixer with 1"1/4 Up&Down waste

TECHNICAL INFO

VASCA - DOCCIA
BATH - SHOWER

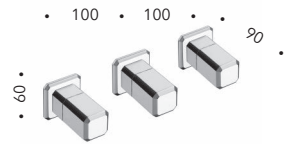

CRIT162 | CRIT163

Set da esterno per miscelatore bicomando doccia/vasca CRICS115 con deviatore 2/3 uscite

3 hole bath/shower mixer external parts for CRICS115 with 2/3 outlet divertere

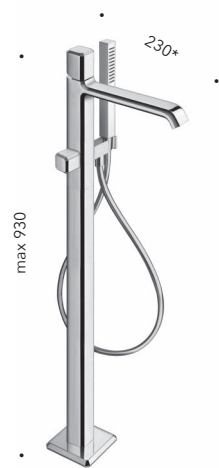

CRIT189

Set da esterno per miscelatore monocomando vasca a pavimento CRICS290 con flessibile LONG LIFE e doccetta anticalcare con miscelazione progressiva indipendente

Floor mounted bath mixer external parts for CRICS290 with LONG LIFE flexible hose and anti-lime hand shower with independent progressive mixing

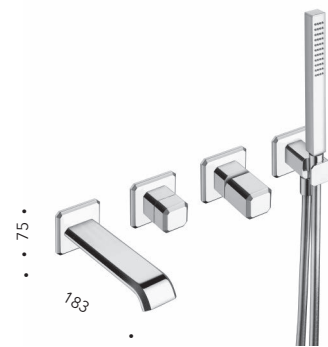

CRIT102 | CRIT103

Set da esterno per miscelatore monocomando doccia/vasca CRICS100 (comando destro) - CRICS101 (comando sinistro) con deviatore 2/3 uscite, doccetta anticalcare in ottone, flessibile LONG LIFE e piastra in metallo

Bath/shower mixer external parts for CRICS100 (right side) - CRICS101 (left side) with 2/3 outlet diverter, LONG LIFE flexible hose, brass anti-lime hand shower and metal plate

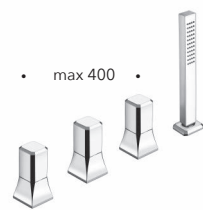

CRIT122

Miscelatore bicomando per bordo vasca 4 fori con doccetta anticalcare estraibile, deviatore 2 uscite e FOLLOW ME

4 hole deck mounted bath mixer with pull-out anti-lime hand shower, 2 outlet diverter and FOLLOW ME

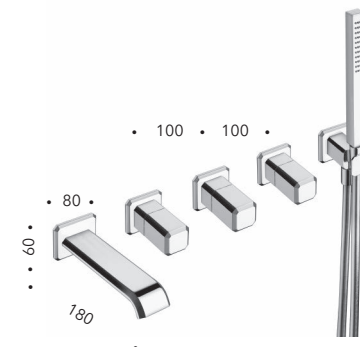

CRIT165

Set da esterno per miscelatore bicomando vasca CRICS115 con deviatore 2 uscite, bocca erogazione, doccetta anticalcare in metallo e flessibile LONG LIFE

3 hole bath mixer external parts for CRICS115 with 2 outlet diverter, spout, metal anti-lime hand shower and LONG LIFE flexible hose

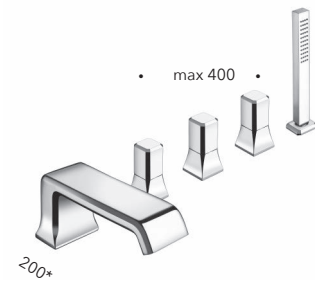

CRIT121

Miscelatore bicomando per bordo vasca 5 fori con deviatore, bocca erogazione, doccetta anticalcare estraibile in metallo e FOLLOW ME

5 hole deck mounted bath mixer with diverter, spout, pull-out metal anti-lime hand shower and FOLLOW ME

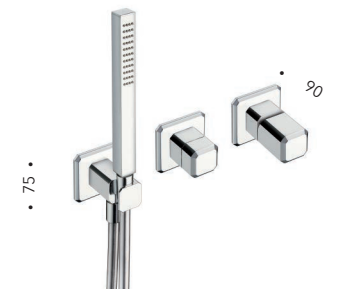

CRIT602 | CRIT603

Set da esterno per miscelatore monocomando doccia/vasca CRICS100 (comando destro) - CRICS101 (comando sinistro) con deviatore 2/3 uscite, doccetta anticalcare in ottone, flessibile LONG LIFE

Bath/shower mixer external parts for CRICS100 (right side) - CRICS101 (left side) with 2/3 outlet diverter, brass anti-lime hand shower, LONG LIFE flexible hose

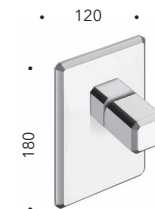

CRIT686

Set da esterno per miscelatore monocomando doccia CRICS535 con piastra in metallo

Shower mixer external parts for CRICS535 with metal plate

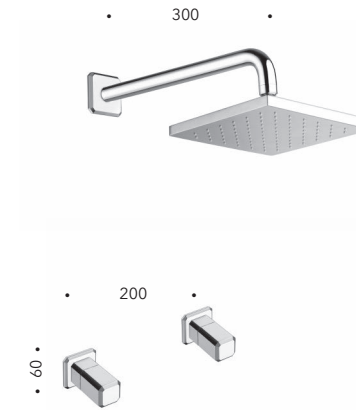

CRIT617

Set da esterno per miscelatore bicomando doccia CRICS233 con soffione anticalcare ispezionabile

Shower mixer external parts for CRICS233 with checkable anti-lime overhead shower



CRIT689

Set da esterno per miscelatore monocomando doccia/vasca CRICS535 con deviatore 2 uscite e piastra in metallo

Bath/shower mixer external parts for CRICS535 with 2 outlet diverter and metal plate



CRIT619

Set da esterno per miscelatore bicomando doccia CRICS115 con soffione anticalcare ispezionabile, doccetta anticalcare in metallo e flessibile LONG LIFE

Shower mixer external parts for CRICS115 with checkable anti-lime overhead shower, metal anti-lime hand shower and LONG LIFE flexible hose

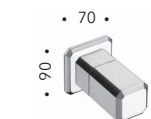

CRIT620

Rubinetto d'arresto da 1/2"

1/2" stopcock

COMBINATIONS

MANOPOLE IN MARMO O PIETRA / MARBLE OR STONE KNOBS /
KNÖPFE IN MARMOR ODER STEIN / POIGNÉES EN MARBRE OU EN PIERRE

CORPO E MANOPOLE IN OTTONE / BRASS BODY AND KNOBS /
MESSINGKÖRPER UND KNÖPFE / CORPS ET POIGNÉES EN LAITON



TOTAL LOOK

CORPO IN OTTONE / BRASS BODY / MESSINGKÖRPER / CORPS EN LAITON

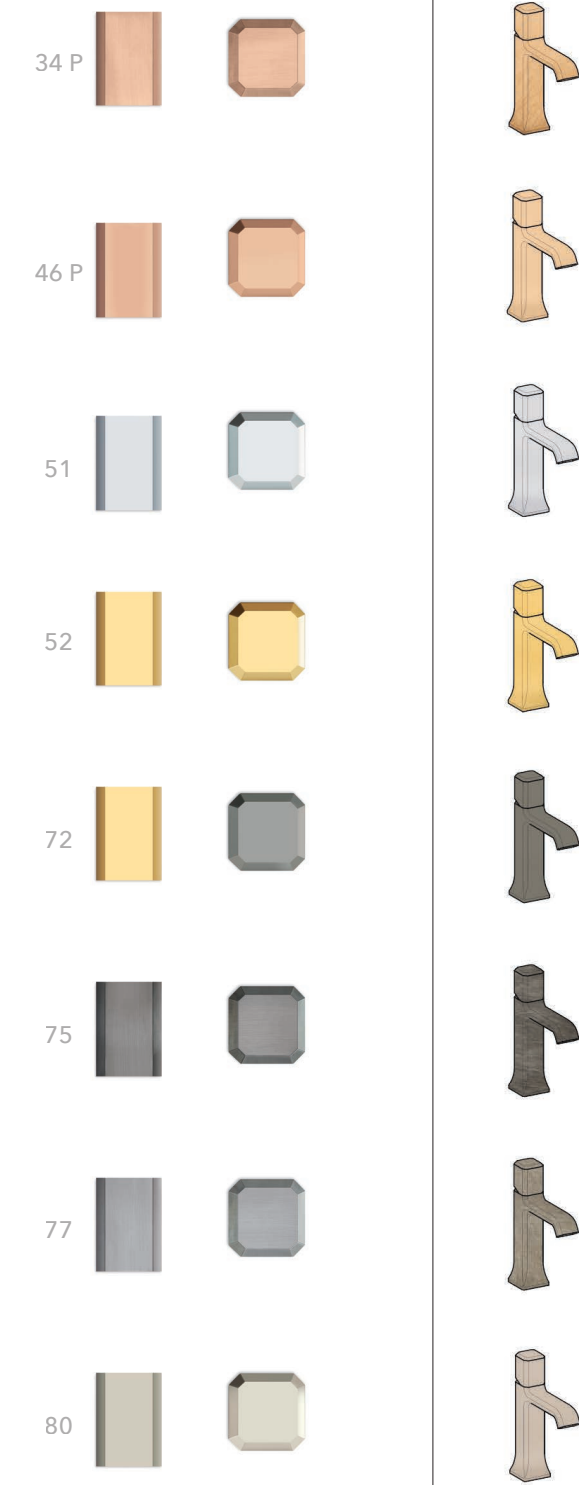
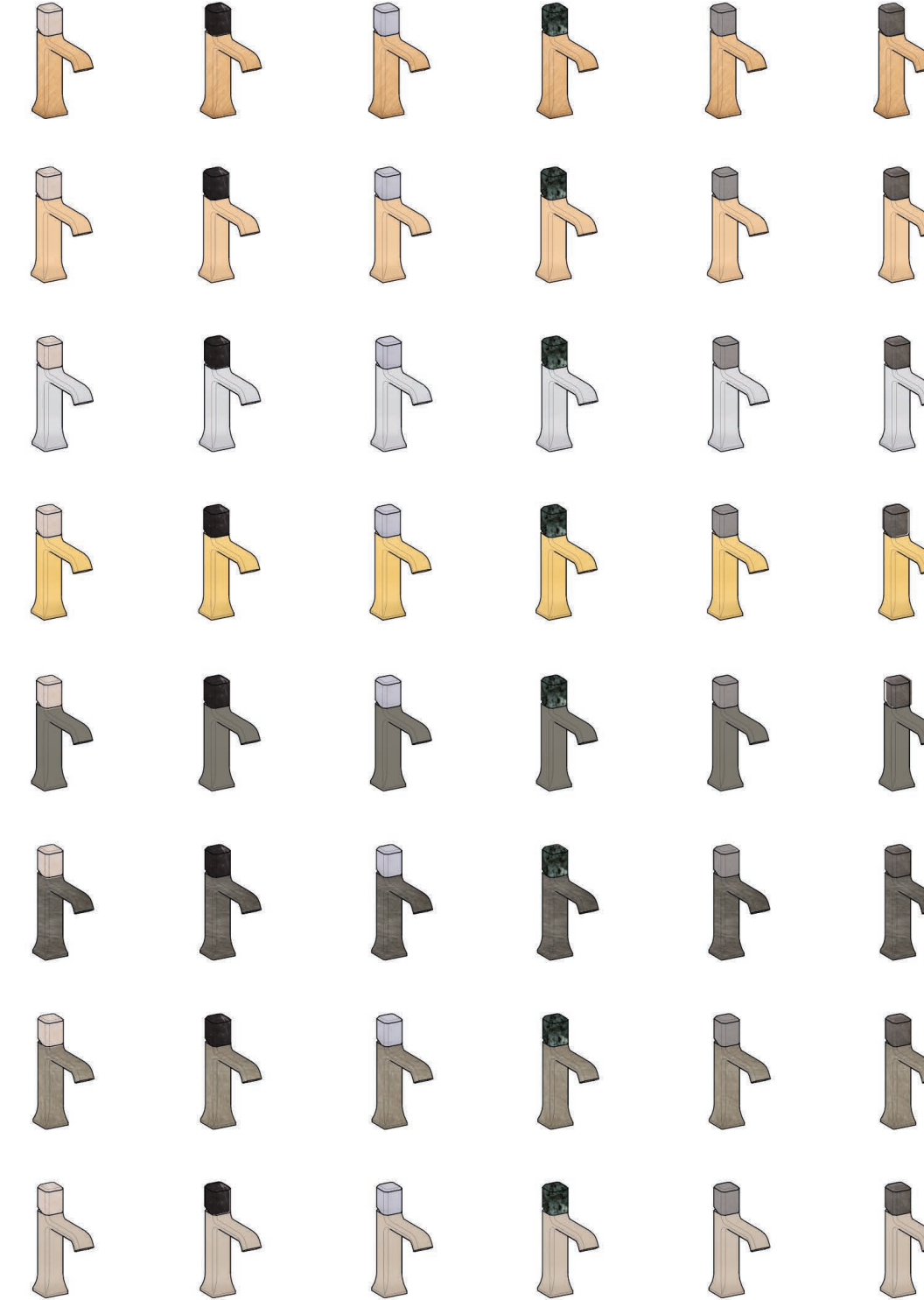

Photographs

FRANCO ROSSI

pag. 3, 6, 9, 11, 21, 22, 31, 40, 41, 42, 51, 52, 57

GIAN PAOLO GIROMINI GRAPHIC DESIGNER

pag. 56, 57, 58, 59, 60, 61

CRISTINA SRL a socio unico

via G. Fava, 56

28024 Gozzano (NO) - Italy

T +39 0322 9545

info@cristinagroup.com

cristinarubinetterie.com



Cristina Srl è in possesso di un Sistema di Gestione Aziendale certificato secondo le norme UNI EN ISO9001:2015 (Qualità) e OH SAS 18001 (Salute e Sicurezza sui luoghi di lavoro).
Cristina Srl has a Company Management System certified according to UNI EN ISO9001:2015 (Quality) and OH SAS 18001 (Health and Safety in the workplace).

Le immagini presenti sul catalogo ADD WATER mostrano una selezione della gamma CRISTINA Rubinetterie. Per l'offerta completa, vi invitiamo a consultare il Product Catalogue CRISTINA 2020.
The pictures shown in ADD WATER catalogue feature an overview of CRISTINA Rubinetterie offer. We invite you to check CRISTINA Product Catalogue 2020, for the complete range.

L'azienda si riserva il diritto di apportare modifiche che riterrà opportune, utili a migliorare la funzionalità e l'estetica dei propri prodotti senza preavviso.
The company reserves the right to make any appropriate modifications to improve functionality and design of its products without notice.

involgia  **CRISTINA**
Curated Bath Brands RUBINETTERIE



Follow us on Instagram



<https://involgia.com>



info@involgia.com